

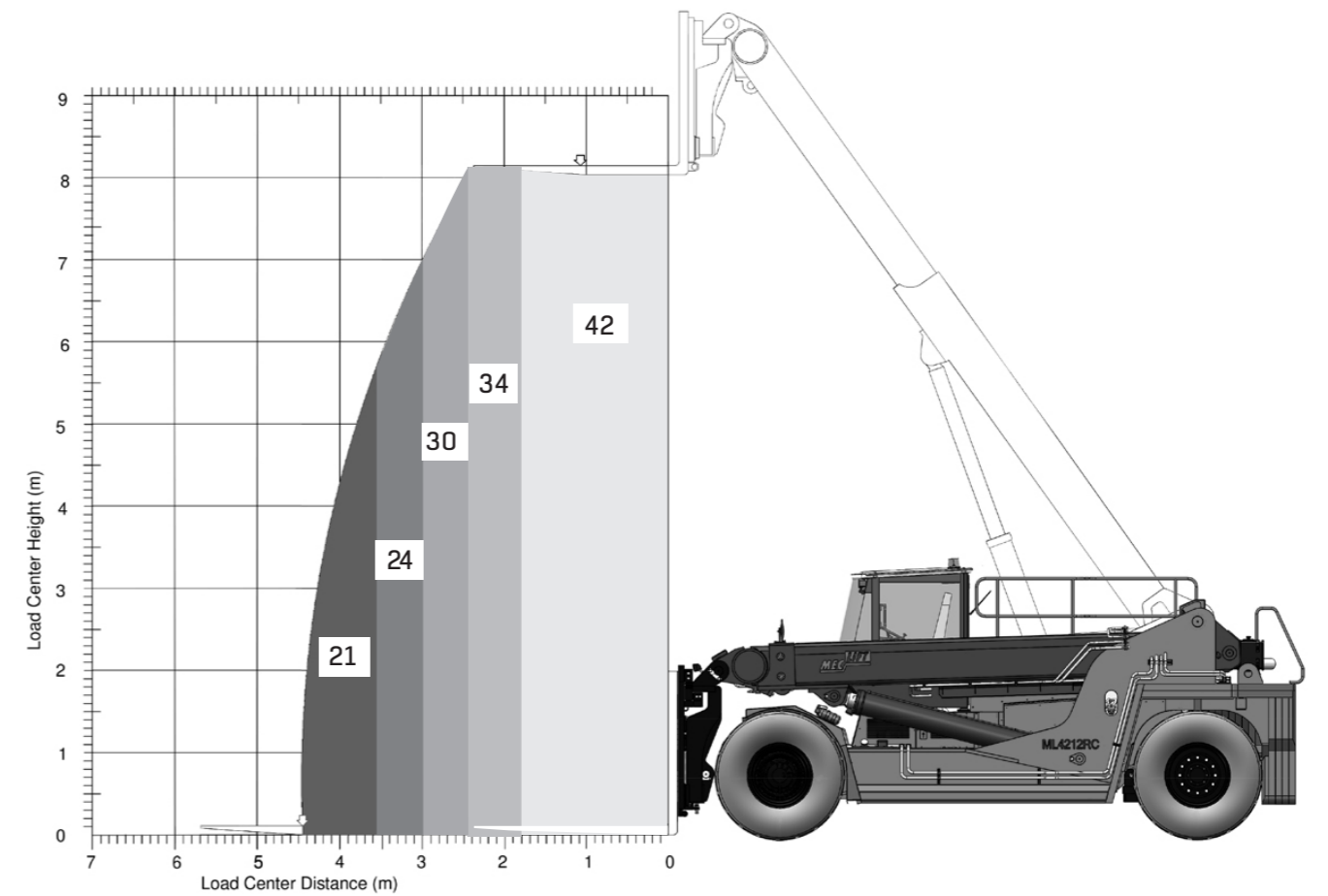

VARIABLE REACH TRUCK ML4218RC



**MULTIPURPOSE
MACHINE THAT
DELIVERS
IN EVERY SITUATION**



VARIABLE REACH TRUCK

ML4218RC is capable of lifting 42 tons with 1.8m load centre, it can reach up to 3,25 meters and taking the lifting height as high as 7,8 meters.

With high lifting and reaching capability, Meclift™ ML4218RC excels on loading/unloading heavy materials into/from containers. It can lift 33t to the middle of a standard container, making all logistical manoeuvres significantly easier and safer. Meclift™ ML4212RC Variable Reach Truck, is designed to help with container loading and unloading. It allows you to do all the heavy lifting into/out of a container on top of a trailer. By using the Bogey Rollers attachment, you can move loads even heavier than 32 tons to the middle of a standard 20ft container.

Meclift™ ML4218RC with the Lifting Beams attachment is a unique combination for long and heavy object handling. By using this attachment, it's possible to place rods, pipes and tubes into the middle of a 40ft container; no other machine in the world can achieve the same!

ML4218RC with fork-mounted top lift spreader, can put 20 - 40ft laden containers on a trailer or a flat wagon.

With the vertically movable cabin, the driver can position himself in the right place, to see either the forks or surrounding areas which enhances occupational safety at the workplace and allows a comfortable operating experience.

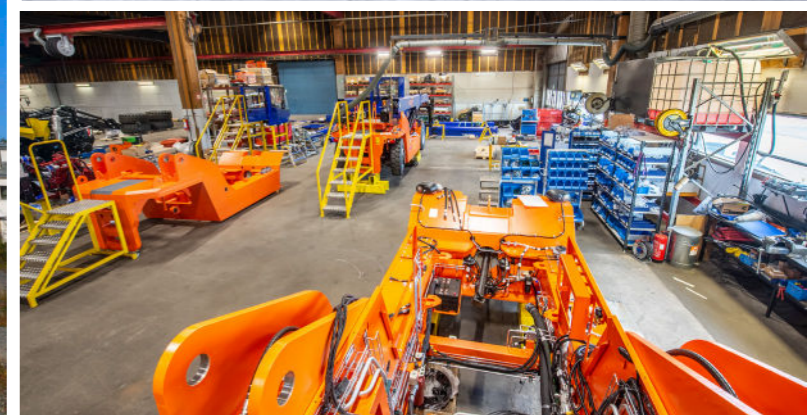
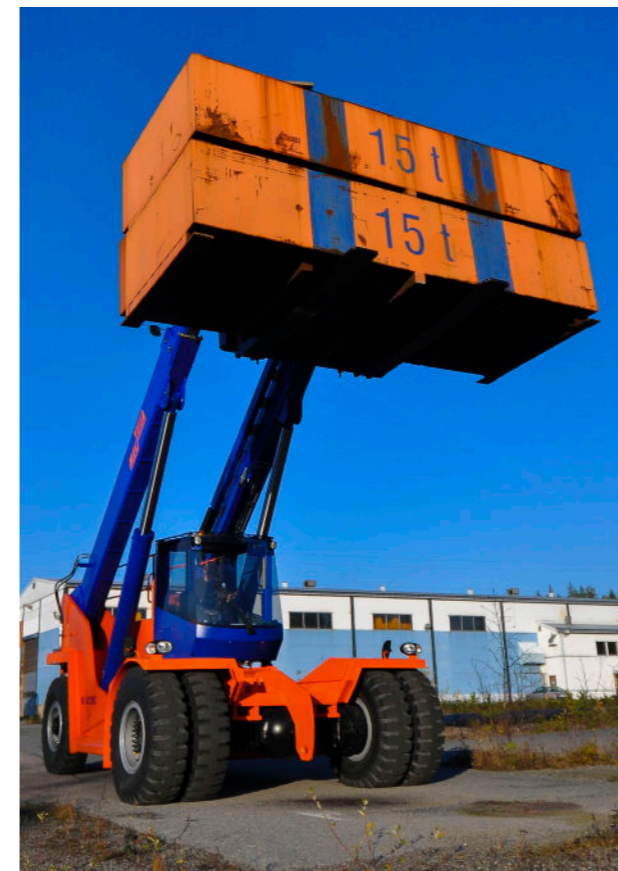

**MECLIFT HANDLES
YOUR CARGO SAFELY**

MECLIFT™ ML4218RC

Manufacturer	Mecalift Oy, Finland
Type	ML4218RC
Standard colors	Orange (RAL2004) and Blue (RAL5002)

Lifting properties	
Lifting capacity	42 000 kg
Load center	1 800 mm
Lifting height	6 000 mm
Reach	3 250 mm
Lifting speed	0.15 m/s

Dimensions	
Length (without attachments)	7 800 mm
Width	3 780 mm
Height (min)	3 485 mm
Wheelbase	5 000 mm
Ground clearance	320 mm
Weight (without attachments)	57 500 kg
Turning radius	8 600 mm
Standard forks W x H x L	300x150x2 400 mm

Technical specifications	
Power source	Diesel engine
Manufacturer	Cummins
Model	QSL9 Stage III/Tier 3
Power rating	242@2100 kW@rpm
Peak torque	1424@1500Nm@rpm
Model	QSL9 Stage V/Tier 4
Power rating	254@2200 kW@rpm
Peak torque	1526@1400Nm@rpm
Transmission	5/3 speed automatic
Manufacturer	ZF
Model	WG 260
Driving speed	25 km/h

Drive axle	
Manufacturer	Kessler
Model	D102PL341/528-NLB
Service brake	Hydraulic wet disc
Parking brake	Spring powered disc

Tyres	
Front	4x480/95R25
Rear	2x480/95R25

- | Options |
|--|
| <ul style="list-style-type: none">- Lifting attachments, i.e. Adjustable Coil Ram, Coil Clamps, Double Forks and Top Spreader for laden containers.- Other options available upon request |

MECLIFT

Mecalift Oy
Hammareninkatu 7
FI-33100 Tampere, Finland
Tel. +358 400 403 593
sales@meclift.fi
meclift.fi

